



# AWP™-4260 PLF

New automated inline processor with processing, drying and light finishing

AWP™-4260 PLF is an automated inline processor designed for AWP™-DEW, composed of an automatic punching device, a processor, a dryer and a light finisher. The machine without a light finisher unit is also available. It is designed to process water-washable AWP™-DEW plates in two standard formats

of 1200x900 mm (48x36 inches) or 1067x1524 mm (42x60 inches) with a thickness from 1,14 to 1,70 mm. AWP™ water-wash technology delivers the smallest carbon footprint from cradle to grave when compared to alternative platemaking technologies.



The AWP™-4260 PLF has a footprint of  
W: 2,070 mm L: 6,114 mm H: 1,295 mm.



WATCH THE  
VIDEO

## The AWP™-4260 PLF processor includes:

- Integrated plate punching system for pin bar
- Integrated air knife after plate rinsing unit to dry the plate
- Backside plate cleaning system
- Auto detergent mixing system
- Integrated filtration system inside machine
- Higher post-exposure uniformity with inline UVA and UVC light finishing
- Filter unit located inside the machine with easy roll-out operator access
- New machine maintenance concept including low maintenance pumps and easy pipe layout
- Water safety tray located on the side frame without the need to clean leaked solution
- Asahi remote human machine interface (HMI) access and optional smart glass support system
- Optimized machine footprint at 6,114 mm x 2,070 mm x 1,295 mm (smaller than separate units)



Stainless steel machine components with roll-out filtration system



Easy water brush supply system



Inline-UV post-exposure ensures high plate uniformity



Operator friendly roll-out tank system for easy access



Magnetic stainless steel pumps for easy maintenance. This pump type does not have a gasket, meaning there is no problem with water leakage



Optional smart glass remote support improves operator efficiency and machine uptime

# New Asahi Maintenance Concept

With the introduction of the new processor, Asahi has also realized the need to improve its AWP™ machine maintenance concept for our customers. As just-in-time production today is very important, the AWP™-4260 PLF processor has a modem communication link to its human machine interface (HMI). This allows our technical support team to connect with the customer machine from any location for first level maintenance support. In addition to tracing the cause of any problem, Asahi also initiated a test for remote smart glass support as a future option to the systems.

A typical support interaction with a customer that took hours of travel time in the past can now pinpoint the detail of a problem in no time, allowing it to be fixed immediately or for the exact spare part to be sent to the customer. When the appropriate part is not available on site for the operator or technician to install, repairs might be delayed, leading to additional costs and a potentially longer machine downtime. Now, everything can be done quickly and in one step, often eliminating the need for any travel at all and getting the equipment up and running quickly, providing higher quality service for our customers.



On-site customer smart glass remote support guided by Asahi Service Engineers

**Contact  
Asahi  
Photoproducts  
today to  
learn more.**

## AWP™-4260 PLF Specifications

Unit	Puncher, Processor, Dryer, Light finisher (Option)
Maximum plate size	2 standard sizes (900x1,200 mm and 1,067x1,524 mm)
Plate thickness	1,14 mm ~ 1,70 mm
Dimension of system	With light finisher: W: 2,070 mm L: 6,114 mm H: 1,295 mm Without light finisher: W: 2,070 mm L: 5,044 mm H: 1,295 mm
Power supply	3Ph 230V/400V 50/60Hz

### 15% space savings with AWP™-4260 PLF

Total equipment space: 22 m<sup>2</sup>

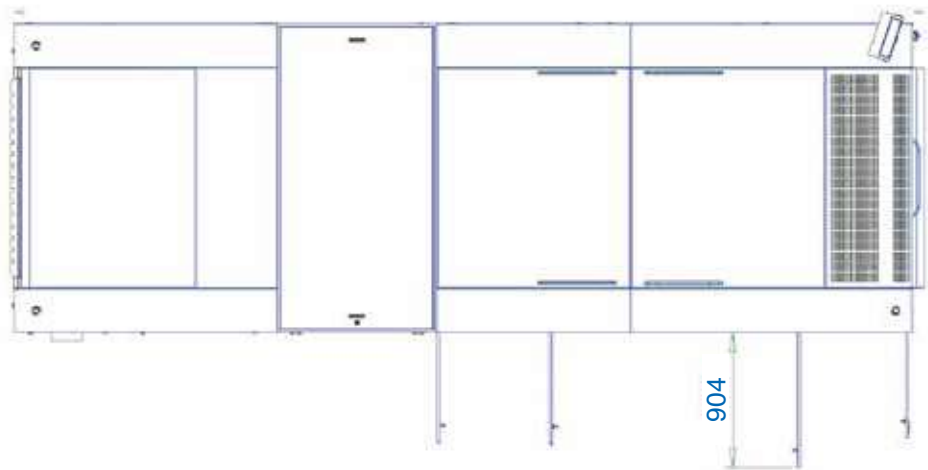
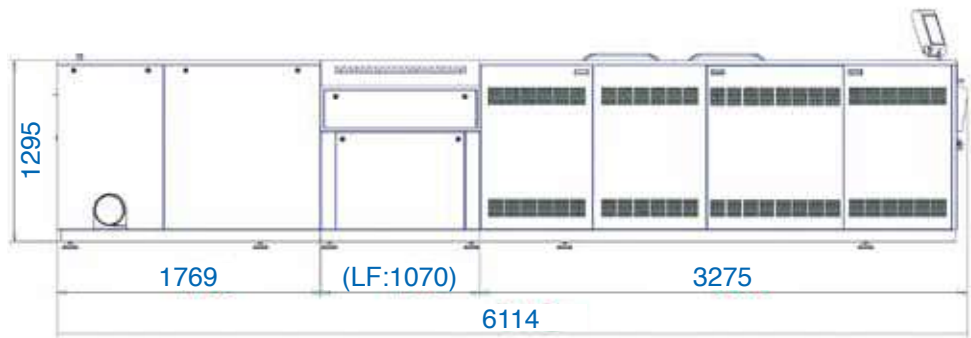
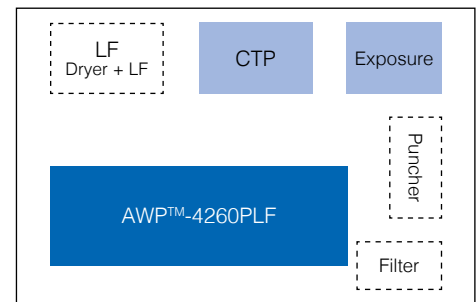
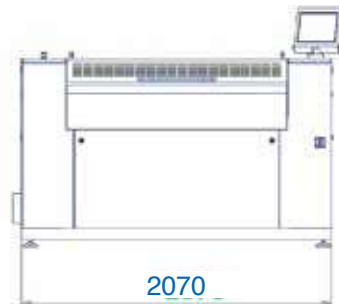

### Asahi Photoproducts

Paepsem Business Park  
Boulevard Paepsem 22  
B-1070 Brussels, Belgium  
Phone: +32 2 526 05 30  
info@asahi-photoproducts.com

### Asahi Kasei Corporation

Photoproducts Division  
1-1-2, Yurakucho, Chiyoda-ku,  
Tokyo 100-0006, Japan  
Phone: +81 3-6699-3353  
info@asahi-photoproducts.com

### Asahi Kasei Electronics Materials (Suzhou), Co. Ltd

Asahi Flexo Technical Center  
261 Xinglong Street,  
Suzhou Industrial Park  
Jiangsu, 215021 China  
Phone: +86-512-62836188-162  
info@asahi-photoproducts.com

### Reduction in platemaking time

	Back Exposure	Imaging	Main Exposure	Washing	Drying	Post Exposure	Total
DEF - 1116PD	1	20	12	82	5	7	127
				87			
DEW + 4260PLF	1	20	12	44	5	8	90
				57			

\* This platemaking time is based on R&D data.  
The actual platemaking time is changed by platemaking condition.

20200818AW